

**CONTROL<sup>TM</sup>  
TECHNIQUES**

**SERVO MOTOR SERIES**

# UNIMOTOR FM

**AC brushless servo motor**

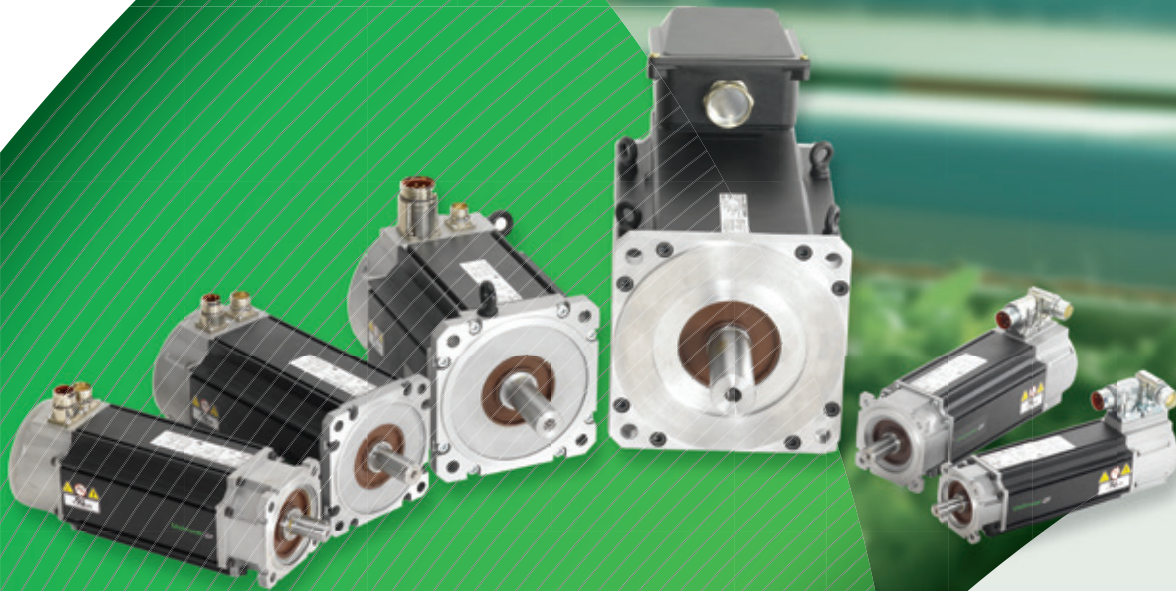

075 to 250 Frames  
1.4 Nm to 136 Nm  
(408 Nm Peak)

**Nidec**

All for dreams

# Unimotor fm

Unimotor fm is a high performance brushless AC servo motor range designed for use in demanding continuous duty applications. The motors are available in six frame sizes with various mounting arrangements and motor lengths.



## Reliability and innovation

Unimotor fm is designed using a proven development process that prioritizes innovation and reliability. This process has resulted in a market leading reputation for both performance and quality.



## Matched motor and drive combinations

Drives and motors from Control Techniques are designed to function as an optimized system. Unimotor fm is the perfect partner for Unidrive M and Digitax ST.



## Faster set-up, optimized performance

When a Control Techniques servo drive is connected to a Unimotor fm fitted with a SinCos or Absolute encoder, it can recognize and communicate with the motor to obtain the "electronic nameplate" data. This motor data can then be used to automatically optimize the drive settings. This feature simplifies commissioning and maintenance, ensures consistent performance and saves time.



## Accuracy and resolution to suit your application requirements

Choosing the right feedback device for your application is critical in getting optimum performance. Unimotor fm has a range of feedback options that offer different levels of accuracy and resolution to suit most applications:

- Resolver: robust for extreme applications and conditions – low accuracy, medium resolution
- Incremental encoder: high accuracy, medium resolution
- Inductive/capacitive SinCos/Absolute: medium accuracy, high resolution
- Optical/SinCos/Absolute: high accuracy, high resolution
- Single turn and multi-turn: Hiperface and EnDat protocols supported



## Ideal for retrofit

Unimotor fm is an ideal retrofit choice with features to ensure it can integrate easily with your existing servo motor applications. Unimotor fm has been designed so that existing Unimotor customers can easily migrate to the new platform. All connector interface types and mounting dimensions remain the same. If you are planning to retrofit your system, Unimotor fm is the obvious choice.

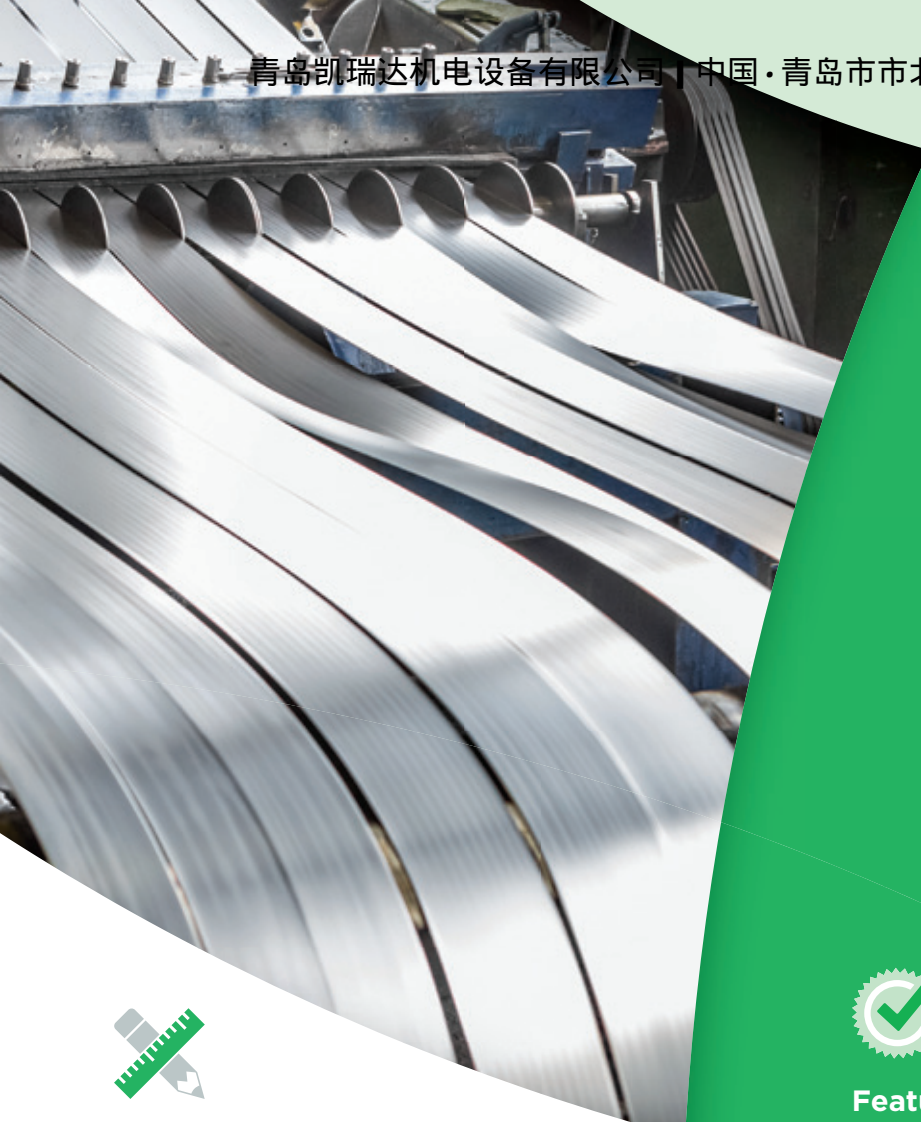

### Custom built motors

As part of our commitment to you, we can design special products to meet your application specific requirements.

Custom built motors are identified by the code -S\*\*\* added to the end of the part number and can include custom shafts, connections or coatings.

e.g. SPZ - Motor is left unpainted  
SON - Motor is fully painted



### Wide range of accessories

In addition we offer a range of accessories to cover your system requirements:

- Feedback and power cables for static and dynamic applications
- Fan boxes
- Gearboxes
- Cable connectors



### Features

Unimotor fm is suitable for a wide range of industrial applications, due to its extensive range of features:

- Torque range from 1.4 Nm to 136 Nm
- High energy parking brakes
- Numerous connector variants, including: vertical, 90° low profile, 90° rotatable and hybrid box on frame size 250
- Variety of flange possibilities (IEC/NEMA)
- Various shaft diameters; keyed or plain
- IP65 conformance; sealed against water spray and dust when mounted and connected
- Low inertia for high dynamic performance; high inertia option available
- World class performance
- Winding voltages for inverter supply of 400 V and 220 V
- Rated speeds from 1,000 to 6,000 rpm and others available
- Thermal protection by PTC thermistor/optional KTY84.130 sensor



**Unimotor fm**



**Quick reference table**

Frame size	PCD (mm)	Unimotor fm												
075	075	1.40 4.70												
		0.78 2.07												
095	100	2.50 9.30												
		1.45 6.0												
115	115	3.9 16.0												
		5.4 14.8												
142	165	6.2 25.0												
		10.2 36.9												
190	215	11.3 77.0												
		31.3 160.8												
250	300	92.0 136												
		275 400												
Stall	(Nm) 0	1.0	3.0	5.0	8.0	10.0	15.0	20.0	30.0	60.0	80.0	100.0	136.0	
Inertia	(kg.cm <sup>2</sup> ) 0	0.8	1.5	2.5	6.5	8.0	9.0	20.0	60.0	100.0	150.0	300.0	400.0	

Conformance and standards



# Ordering information - D + 10 lead time

Use the information below in the illustration to create an order code for a Unimotor fm.

075	U	3	B	30	0	B
Frame size	Motor voltage	Magnet type	Stator length	Rated speed	Brake	Connection type
	075-142 frame	075-142 frame	075 frame	075-142 frame	075 - 142 frame	Size 1
075	U = 400V	3 = Standard	B/D	30 = 3000 rpm	0 = Not fitted (Std)	B = Power and signal 90° rotatable
095			095 frame		5 = Parking brake (fibre)	C = Power 90° rotatable and signal vertical
115			B/C/D		6 = Parking brake (resin)	V = Power and signal vertical
142			115 frame			Size 1.5
			B/C/D			J = Power and signal 90° rotatable
			142 frame		N = Power 90° rotatable and signal vertical	
	C/D/E	M = Power and signal vertical				

Express availability motors, available in ten days ex works

## ORDERING INFORMATION - STANDARD LEAD TIME

Additional options are available upon request but may require a longer lead time to complete, please check with the Automation Center.

095	U	3	B	40	0	B
Frame size	Motor voltage	Magnet type	Stator length	Rated speed	Brake	Connection type <sup>1</sup>
	075-190 frame	075-250 frame	075 frame	075-190 frame	075 - 142 frame	Size 1
075	E = 220V	3 = Standard	A - C	20 = 2000 rpm	0 = Not fitted (Std)	B = Power and signal 90° rotatable
095	U = 400V		095 - 142	40 = 4000 rpm	5 = Parking brake (fibre)	C = Power 90° rotatable and signal vertical
115	250 frame	6 = Peak	A - E	60 = 6000 rpm*	6 = Parking brake (resin)	V = Power and signal vertical
142	U = 400V		190	250 frame	X = Special	D = Single cable, power & signal combined, 90° rotatable
190			A - H	10 = 1000 rpm		Size 1.5
250			250*	15 = 1500 rpm		J = Power and signal 90° rotatable
			D - F	20 = 2000 rpm		N = Power 90° rotatable and signal vertical
			25 = 2500 rpm		M = Power and signal vertical	
					E = Single cable, power & signal combined, 90° rotatable	
					Hybrid box	
					H = Power hybrid box	
					X = Special	

### Notes:

- \*6000rpm only available on certain lengths
- \*250 D and E lengths, winding speed equal and above 2500rpm must use the hybrid box
- \*250 F lengths, winding speed equal and above 2000rpm must use the hybrid box
- 190 - Lifting eyes will be fitted as standard on all 190 motors. This is to enable easy handling of these motors that are often over 25 kg in weight. If there is an issue with the lifting eyes causing an obstruction when fitting the mating cable then the lifting eyes may be removed once the motor is installed in the application.
- Hybrid Box Connection - Due to the increased power rating of some of the 190 motors a hybrid box is now being offered. A motor fitted with a hybrid box will not be UL marked. If a specific motor from the fm range that now has a hybrid box has previously been purchased with a connector and is working within an application please contact Control Techniques Dynamics to discuss options available.
- Single Cable must be fitted with KTY thermistor and is only available with certain feedback options and not all frame sizes. Please check before ordering.

A	CA		A	100		190	
Output shaft	Feedback device		Inertia	PCD		Shaft diameter	
<b>075 - 142 frame</b>	<b>075 - 142 frame</b>		<b>075 - 142 frame</b>	<b>075 frame only</b>			
<b>A</b> = Key	<b>AE</b> = Resolver		<b>A</b> = Standard + PTC	<b>075</b>	Std	<b>14.0</b>	B/C
<b>B</b> = Plain shaft	<b>CA</b> = Incremental Encoder	CFS50	<b>B</b> = High + PTC	<b>095 frame only</b>			
	<b>EC</b> = Inductive EnDat SinCos Multi-turn	EQI 1331		<b>100</b>	Std	<b>19.0</b>	B/C/D
	<b>FC</b> = Inductive EnDat SinCos Single-turn	ECI 1319		<b>115 frame only</b>			
	<b>RA</b> = Optical Hiperface SinCos Multi-turn	SRM 50		<b>115</b>	Std	<b>19.0</b>	B/C
				<b>115</b>	Std	<b>24.0</b>	D
				<b>142 frame only</b>			
				<b>165</b>	Std	<b>24.0</b>	C/D/E

A	CA		A	100		190	
Output shaft	Feedback device		Inertia	PCD		Shaft diameter	
<b>075 - 250 frame</b>	<b>075 - 250 frame</b>		<b>075 - 190 frame</b>	<b>075 frame only</b>			
<b>A</b> = Key	<b>AE</b> = Resolver		<b>A</b> = Standard + PTC <sup>2</sup>	<b>075</b>	Std	<b>11.0</b>	A
<b>B</b> = Plain shaft	<b>CA</b> = Incremental Encoder	CFS50	<b>B</b> = High + PTC	<b>080</b>		<b>14.0</b>	B-D
<b>E</b> = Key with half key fitted	<b>EC</b> = Inductive EnDat SinCos Multi-turn	EQI 1331	<b>C</b> = Standard + KTY <sup>3</sup>	<b>085</b>		<b>19.0</b>	Max
<b>F</b> = Key and half key supplied separately	<b>FC</b> = Inductive EnDat SinCos Single-turn	ECI 1319	<b>D</b> = High + KTY			<b>XXX=</b>	Special
	<b>EF</b> = Inductive EnDat Multi-turn FS	EQI 1331 FS	<b>X</b> = Special	<b>095 frame only</b>			
	<b>FF</b> = Inductive EnDat Single-turn FS	ECI 1319 FS	<b>250 frame</b>	<b>100</b>	Std	<b>14.0</b>	A
	<b>RA</b> = Optical Hiperface SinCos Multi-turn	SRM 50	<b>A</b> = Standard + PTC	<b>098</b>		<b>19.0</b>	B-E
	<b>SA</b> = Optical Hiperface SinCos Single-turn	SRS 50	<b>C</b> = Standard + KTY	<b>115</b>		<b>22.0</b>	Max
	<b>EB</b> = Optical EnDat SinCos Multi-turn	EQN 1325	<b>D</b> = High + KTY			<b>XXX=</b>	Special
	<b>FB</b> = Optical EnDat SinCos Single-turn	ECN 1313	<b>X</b> = Special	<b>115 frame only</b>			
	<b>NA</b> = Sensorless			<b>115</b>	Std	<b>19.0</b>	A-C
	<b>XX</b> = Specials			<b>130</b>		<b>24.0</b>	D/E
						<b>24.0</b>	Max
						<b>XXX=</b>	Special
				<b>142 frame only</b>			
				<b>165</b>	Std	<b>24.0</b>	A/E
				<b>149</b>		<b>32.0</b>	Max
						<b>XXX=</b>	Special
				<b>190 frame only</b>			
				<b>215</b>	Std	<b>32.0</b>	A-H
						<b>42.0</b>	Max
						<b>XXX=</b>	Special
				<b>250 frame only</b>			
				<b>300</b>	Std	<b>48.0</b>	D-F

**Notes:**

- <sup>1</sup>Not all options are available on all frames sizes, please check before ordering
- Shaft sizing - Please ensure that the correct shaft size is selected to meet the application requirement.
- 142 Connector Rating - Due to the increased power rating of some of the 142 motors a type "J" or "M" size 1.5 power connector is now being offered. If a specific motor from the fm range that now has a "J" or "M" type connector has previously been purchased with a "B" or "C" or "V" size 1 connector and is working within an application please contact Control Techniques Dynamics to discuss the options available.
- Sensorless mode - Motor performance will be limited at low speed, please read feedback selection for details.
- Other feedback options available on request but may increase motor lead time. Please check before ordering.

<sup>2</sup>PTC thermistor = DIN44082

<sup>3</sup>KTY thermistor = KTY84

# Ratings

**3 Phase VPWM drives 200-240Vrms** -  $\Delta t = 100^{\circ}\text{C}$  winding  $40^{\circ}\text{C}$  maximum ambient.

All data subject to +/-10% tolerance

Motor Frame Size (mm)	O75E3				O95E3					115E3				
Frame length	A	B	C	D	A	B	C	D	E	A	B	C	D	E
Continuous stall torque (Nm)	1.4	2.7	3.7	4.7	2.5	4.5	6.3	7.9	9.3	3.9	7.4	10.8	13.7	16
Standard (3) Peak torque (Nm)	4.3	8	11.2	14	7.4	13.5	18.9	23.7	27.8	11.7	22.2	32.4	41	48
High (6) Peak torque (Nm)	7.2	13.3	18.6	23.4	11	20.3	28.4	35.6	41.6	15.6	29.6	43.2	54.6	64
Standard inertia (kg cm <sup>2</sup> )	0.78	1.22	1.64	2.07	1.45	2.6	3.72	4.83	6	5.4	7.7	10	12.5	14.8
High Inertia (kg cm <sup>2</sup> )	1.18	1.61	2.03	2.46	3.31	4.5	5.6	6.7	7.8	10	12.3	14.7	17.1	19.4
Winding thermal time constant (sec)	63	58	73	78	84	82	90	108	112	103	109	116	127	141
Standard motor weight (kg)	2.88	3.68	4.48	5.28	4.49	5.75	7.01	8.27	9.53	6.88	8.68	10.48	12.28	14.08
Number of poles	6	6	6	6	6	6	6	6	6	6	6	6	6	6
Speed 2000 (rpm)	Kt(Nm/A) = 1.4													
	Ke(V/Krpm) = 85.5													
Rated torque (Nm)	1.3	2.5	3.5	4.5	2.4	4.3	5.9	7.3	8.5	3.7	7.3	10.1	11.9	14.1
Stall current (A)	1	1.9	2.7	3.3	1.8	3.2	4.5	5.6	6.6	2.8	5.3	7.7	9.8	11.4
Rated power (kW)	0.27	0.52	0.73	0.93	0.51	0.9	1.23	1.53	1.77	0.77	1.53	2.12	2.49	2.95
R (ph-ph) (Ohms)	48.24	16.32	8.96	6.22	20.69	6.78	3.79	2.42	1.92	10.65	3.43	1.82	1.81	1.34
L (ph-ph) (mH)	87.47	39.77	24.68	19.15	57.78	26.10	16.36	11.83	9.75	55.83	19.43	12.31	9.50	7.68
Recommended power conn' size	1	1	1	1	1	1	1	1	1	1	1	1	1	1
Speed 3000 (rpm)	Kt(Nm/A) = 0.93													
	Ke(V/Krpm) = 57													
Rated Torque (Nm)	1.3	2.3	3.3	4.2	2.33	4.1	5.6	6.9	8.15	3.5	6.7	9.5	11.2	12.7
Stall Current (A)	1.55	2.85	4	5.02	2.63	4.84	6.77	8.49	9.95	4.19	7.96	11.61	14.68	17.2
Rated Power (kW)	0.41	0.72	1.04	1.31	0.73	1.29	1.76	2.17	2.56	1.1	2.1	2.98	3.52	3.99
R (ph-ph) (Ohms)	19.80	6.69	3.71	2.72	9.62	2.99	1.64	1.07	0.86	4.91	1.52	0.81	0.57	0.43
L (ph-ph) (mH)	37.20	16.8	10.69	8.27	26.29	11.47	7.15	5.16	4.35	20.26	8.63	5.47	4.35	3.41
Recommended power conn' size	1	1	1	1	1	1	1	1	1	1	1	1	1	HYBRID
Speed 4000 (rpm)	Kt(Nm/A) = 0.7													
	Ke(V/Krpm) = 42.75													
Rated Torque (Nm)	1.2	2.1	2.8	3.8	2.3	3.8	5.3	6.4	7.4	3	5.8	7.5	8.3	8.8
Stall Current (A)	2.06	3.79	5.31	6.67	3.5	6.43	9	11.29	13.21	5.57	10.57	15.43	19.5	22.86
Rated Power (kW)	0.5	0.86	1.17	1.59	0.94	1.59	2.2	2.68	3.1	1.26	2.43	3.12	3.46	3.69
R (ph-ph) (Ohms)	12.44	4.01	2.26	1.53	5.26	1.76	1.04	0.74	0.48	3.05	0.93	0.49	0.3	0.27
L (ph-ph) (mH)	23.35	9.62	6.32	4.63	14.94	6.67	4.52	3.53	2.44	12.44	5.13	3.34	2.25	2.18
Recommended power conn' size	1	1	1	1	1	1	1	1	1	1	1	1	1	HYBRID
Speed 6000 (rpm)	Kt(Nm/A) = 0.47													
	Ke(V/Krpm) = 28.5													
Rated Torque (Nm)	1.1	1.9	2.8	3.4	1.98	3.2	4.2	N/A	N/A	2.7	5			
Stall Current (A)	3.06	5.64	7.91	9.94	5.21	9.57	13.4			8.3	15.74			
Rated Power (kW)	0.68	1.21	1.73	2.14	1.24	2.01	2.64			1.7	3.14			
R (ph-ph) (Ohms)	5.37	1.81	1.02	0.68	2.33	0.73	0.46			1.5	0.41			
L (ph-ph) (mH)	9.8	4.42	2.88	2.06	6.57	2.77	2.07			6.08	2.34			
Recommended power conn' size	1	1	1	1	1	1	1			1	1			

- N/A Not available
- The information contained in this specification is for guidance only and does not form part of any contract.
- Control Techniques have an ongoing process of development and reserves the right to change the specification without notice.
- Stall torque, rated torque and power relate to maximum operation tested in a 20 °C ambient at 12 kHz drive switching frequency.



CE6001 iss 26

142E3					190E3								Motor Frame Size (mm)	
A	B	C	D	E	A	B	C	D	E	F	G	H	Frame length	
6.2	11	15.7	20.5	25	11.3	22.5	33.5	44.5	54	63	71	77	Continuous stall torque (Nm)	
18.6	33	47.1	61.5	75	33.8	67.5	100.5	133.5	162	189	213	231	Standard (3) Peak torque (Nm)	
24.8	44	62.8	82	100	N/A	N/A	N/A	N/A	N/A	N/A	N/A	N/A	High (6) Peak torque (Nm)	
10.2	16.9	23.5	30.2	36.9	31.3	49.8	68.3	86.8	105.3	123.8	142.3	160.8	Standard inertia (kg cm <sup>2</sup> )	
23.2	29.8	36.5	43.1	49.8	69.8	88.3	106.8	125.3	143.8	162.3	180.8	199.3	High Inertia (kg cm <sup>2</sup> )	
145	148	188	206	249	194	214	215	216	251	285	425	564	Winding thermal time constant (sec)	
8.81	11.66	14.51	17.36	20.21	12.62	18.08	23.54	28.99	34.44	39.9	45.35	50.81	Standard motor weight (kg)	
6	6	6	6	6	8	8	8	8	8	8	8	8	Number of poles	
Kt(Nm/A) = 1.4													Speed 2000 (rpm)	
Ke(V/Krpm) = 85.5														
5.9	10.4	14.7	18.5	21.5	10.8	20.6	29.4	37.9	44.3	50.5	54	56	Rated torque (Nm)	
4.4	7.9	11.2	14.6	17.9	8	16.1	23.9	31.8	38.6	45	50.7	55	Stall current (A)	
1.23	2.18	3.08	3.87	4.49	2.26	4.31	6.15	7.94	9.28	10.58	11.31	11.73	Rated power (kW)	
5.56	1.54	0.8	0.51	0.4	1.81	0.50	0.25	0.19	0.13	0.1	0.08	0.05	R (ph-ph) (Ohms)	
35.43	14.25	8.99	6.35	5.25	17.34	7.77	4.66	3.26	3.02	2.65	2.13	1.55	L (ph-ph) (mH)	
1	1	1	1	1.5	1.5	1.5	1.5	1.5	1.5	HYBRID ONLY			Recommended power conn' size	
Kt(Nm/A) = 0.93													Speed 3000 (rpm)	
Ke(V/Krpm) = 57														
5.5	9.5	12.8	16	18.15	10.3	19.4	26.5	33.2	34.2	35.2	36.2	37	Rated Torque (Nm)	
6.67	11.83	16.88	22.04	26.88	12.1	24.19	36.02	47.85	58.06	67.74	76.34	82.8	Stall Current (A)	
1.73	2.98	4.02	5.03	5.7	3.24	6.09	8.33	10.43	10.74	11.06	11.37	11.62	Rated Power (kW)	
2.25	0.68	0.35	0.23	0.16	0.83	0.26	0.13	0.09	0.07	0.05	0.05	0.03	R (ph-ph) (Ohms)	
14.68	6.33	3.89	3.66	2.23	7.94	3.87	2.46	1.81	1.55	1.17	1.36	0.88	L (ph-ph) (mH)	
1	1	1	1.5	1.5	1.5	1.5	1.5	HYBRID ONLY					Recommended power conn' size	
Kt(Nm/A) = 0.7													Speed 4000 (rpm)	
Ke(V/Krpm) = 42.75														
4.1	8.1	10.2	12.2	14	8.2	18.2	23	29	N/A	N/A	N/A	N/A	Rated Torque (Nm)	
8.86	15.71	22.43	29.29	35.71	16.07	32.14	47.86	63.57					Stall Current (A)	
1.72	3.37	4.27	5.11	5.86	3.43	7.62	9.63	12.15					Rated Power (kW)	
1.29	0.38	0.23	0.13	0.09	0.46	0.14	0.07	0.06					R (ph-ph) (Ohms)	
8.39	3.44	2.49	1.99	1.2	4.34	2.18	1.39	1.26					L (ph-ph) (mH)	
1	1	1.5	1.5	1.5	1.5	1.5	HYBRID ONLY						Recommended power conn' size	
Kt(Nm/A) = 0.47													Speed 6000 (rpm)	
Ke(V/Krpm) = 28.5														
3.2	N/A	N/A	N/A	N/A	N/A	N/A	N/A	N/A	N/A	N/A	N/A	N/A	Rated Torque (Nm)	
13.19													Stall Current (A)	
2.01													Rated Power (kW)	
0.56													R (ph-ph) (Ohms)	
3.67													L (ph-ph) (mH)	
1													Recommended power conn' size	

- All other figures relate to a 20 °C motor temperature. Maximum intermittent winding temperature is 140 °C.
- The recommended connector has to be selected using the connector manufacturer's de-rating values applied to a motor at full operational temperature.

# Ratings

**Phase VPWM drives 380 - 480 Vrms** -  $\Delta t = 100\text{ }^{\circ}\text{C}$  winding  $40\text{ }^{\circ}\text{C}$  maximum ambient.  
All data subject to  $\pm 10\%$  tolerance

Motor Frame Size (mm)	075U3				095U3					115U3				
Frame length	A	B	C	D	A	B	C	D	E	A	B	C	D	E
Continuous stall torque (Nm)	1.4	2.7	3.7	4.7	2.5	4.5	6.3	7.9	9.3	3.9	7.4	10.8	13.7	16
Standard (3) Peak torque (Nm)	4.3	8	11.2	14	7.4	13.5	18.9	23.7	27.8	11.7	22.2	32.4	41	48
High (6) Peak torque (Nm)	7.2	13.3	18.6	23.4	11	20.3	28.4	35.6	41.6	15.6	29.6	43.2	54.6	64
Standard inertia (kg cm <sup>2</sup> )	0.78	1.22	1.64	2.07	1.45	2.6	3.72	4.83	6	5.4	7.7	10	12.5	14.8
High Inertia (kg cm <sup>2</sup> )	1.18	1.61	2.03	2.46	3.31	4.5	5.6	6.7	7.8	10	12.3	14.7	17.1	19.4
Winding thermal time constant (sec)	63	58	73	78	84	82	90	108	112	103	109	116	127	141
Standard motor weight (kg)	2.88	3.68	4.48	5.28	4.49	5.75	7.01	8.27	9.53	6.88	8.68	10.48	12.28	14.08
Number of poles	6	6	6	6	6	6	6	6	6	6	6	6	6	6
Speed 2000 (rpm)	Kt (Nm/A) = 2.4													
	Ke (V/Krpm) = 147													
Rated torque (Nm)	1.3	2.5	3.5	4.5	2.4	4.3	5.9	7.3	8.5	3.7	7.3	10.1	11.9	14.1
Stall current (A)	0.6	1.1	1.6	1.9	1	1.9	2.6	3.3	3.9	1.6	3.1	4.5	5.7	6.7
Rated power (kW)	0.27	0.52	0.73	0.93	0.51	0.9	1.23	1.53	1.77	0.77	1.53	2.12	2.49	2.95
R (ph-ph) (Ohms)	148.5	52.2	27.3	19.97	64.08	20.88	10.46	7.46	5.09	32.92	10.68	5.25	3.7	2.75
L (ph-ph) (mH)	258.36	117.28	74.2	56.97	173.4	78.16	47.02	35.44	27.18	139.43	59.51	35.9	27.63	21.87
Recommended power conn' size	1	1	1	1	1	1	1	1	1	1	1	1	1	1
Speed 3000 (rpm)	Kt (Nm/A) = 1.6													
	Ke (V/Krpm) = 98													
Rated Torque (Nm)	1.3	2.3	3.3	4.2	2.3	4.1	5.6	6.9	8.2	3.5	6.7	9.5	11.2	12.7
Stall Current (A)	0.9	1.7	2.3	2.9	1.5	2.8	3.9	4.9	5.8	2.4	4.6	6.8	8.5	10
Rated Power (kW)	0.41	0.72	1.04	1.31	0.73	1.29	1.76	2.17	2.56	1.1	2.1	2.98	3.52	3.99
R (ph-ph) (Ohms)	62.08	21.07	12.54	7.81	26.7	8.63	4.67	3.16	2.27	14.74	4.37	2.3	1.53	1.23
L (ph-ph) (mH)	114.59	52.65	34.18	23.89	76.65	33.71	21.09	15.95	12.06	57.29	25.19	15.57	11.6	9.89
Recommended power conn' size	1	1	1	1	1	1	1	1	1	1	1	1	1	1
Speed 4000 (rpm)	Kt (Nm/A) = 1.2													
	Ke (V/Krpm) = 73.5													
Rated Torque (Nm)	1.2	2.1	2.8	3.8	2.3	3.8	5.3	6.4	7.4	3	5.8	7.5	8.3	8.8
Stall Current (A)	1.2	2.2	3.1	3.9	2	3.8	5.3	6.6	7.7	3.3	6.2	9	11.4	13.3
Rated Power (kW)	0.5	0.86	1.17	1.59	0.94	1.59	2.2	2.68	3.1	1.26	2.43	3.12	3.46	3.69
R (ph-ph) (Ohms)	38.01	12.71	6.49	4.94	16.14	5.22	2.61	1.81	1.4	8.49	2.61	1.31	0.84	0.66
L (ph-ph) (mH)	68.39	30.46	18.28	13.97	44.25	19.54	11.75	8.86	7.25	33.79	14.87	8.98	6.27	5.35
Recommended power conn' size	1	1	1	1	1	1	1	1	1	1	1	1	1	1
Speed 6000 (rpm)	Kt (Nm/A) = 0.8													
	Ke (V/Krpm) = 49													
Rated Torque (Nm)	1.1	1.9	2.8	3.4	2	3.2	4.2	N/A	N/A	2.7	5	N/A	N/A	N/A
Stall Current (A)	1.8	3.3	4.7	5.8	3.1	5.6	7.9			4.9	9.3			
Rated Power (kW)	0.68	1.21	1.73	2.14	1.24	2.01	2.64			1.7	3.14			
R (ph-ph) (Ohms)	15.48	5.19	2.86	2.12	6.59	2.13	1.22			3.48	1.09			
L (ph-ph) (mH)	28.66	12.77	8.01	6.33	18.62	8.24	5.44			14.31	6.3			
Recommended power conn' size	1	1	1	1	1	1	1			1	1			

- N/A Not available
- The information contained in this specification is for guidance only and does not form part of any contract.
- Control Techniques have an ongoing process of development and reserves the right to change the specification without notice.
- Stall torque, rated torque and power relate to maximum operation tested in a 20 °C ambient at 12 kHz drive switching frequency.
- All other figures relate to a 20 °C motor temperature. Maximum intermittent winding temperature is 140 °C.
- The recommended connector has to be selected using the connector manufacturer's de-rating values applied to a motor at full operational temperature.

**CE6001 iss 26**

142U3					190U3								250U3			Motor Frame Size (mm)	
A	B	C	D	E	A	B	C	D	E	F	G	H	D	E	F	Frame length	
6.2	11	15.7	20.5	25	11.3	22.5	33.5	44.5	54	63	71	77	92	116	136	Continuous stall torque (Nm)	
18.6	33	47.1	61.5	75	33.8	67.5	100.5	133.5	162	189	213	231	276	348	408	Standard (3) Peak torque (Nm)	
24.8	44	62.8	82	100	N/A	N/A	N/A	N/A	N/A	N/A	N/A	N/A	N/A	N/A	N/A	High (6) Peak torque (Nm)	
10.2	16.9	23.5	30.2	36.9	31.3	49.8	68.3	86.8	105.3	124	142.3	160.8	275	337	400	Standard inertia (kg cm <sup>2</sup> )	
23.2	29.8	36.5	43.1	49.8	69.8	88.3	106.8	125.3	143.8	162.3	180.8	199.3	408	502	597	High inertia (kg cm <sup>2</sup> )	
145	148	188	206	249	194	214	215	216	251	285	425	564	439	486	608	Winding thermal time constant (sec)	
8.81	11.66	14.51	17.36	20.21	12.62	18.08	23.54	28.99	34.44	39.9	45.35	50.81	57.5	65.5	73.7	Standard motor weight (kg)	
6	6	6	6	6	8	8	8	8	8	8	8	8	10	10	10	Number of poles	
Kt (Nm/A) = 2.4													Kt (Nm/A) = 5.4			Speed 1,000 (rpm)	
Ke (V/Krpm) = 147													Ke (V/krpm) = 323				
5.9	10.4	14.7	18.5	21.5	10.8	20.6	29.4	37.9	44.3	50.5	54	56	75	92	106	Rated torque (Nm)	
2.6	4.6	6.5	8.5	10.4	4.7	9.4	14	18.5	22.5	26.3	29.6	32.1	17.2	21.7	25.4	Stall current (A)	
1.23	2.18	3.08	3.87	4.49	2.26	4.31	6.15	7.94	9.28	10.58	11.31	11.73	7.9	9.6	11.1	Rated power (kW)	
14.64	4.71	2.38	1.60	1.11	6.15	1.54	0.83	0.5	0.37	0.28	0.26	0.23	0.61	0.48	0.34	R (ph-ph) (Ohms)	
98.76	42.15	26.32	19.46	15.08	52.90	23.55	15	8.81	8.68	7.36	6.89	6.3	22.9	19.1	14.9	L (ph-ph) (mH)	
1	1	1	1	1	1.5	1.5	1.5	1.5	1.5	1.5	1.5	1.5	1.5	1.5	1.5	Recommended power conn' size	
Kt (Nm/A) = 1.6													Kt (Nm/A) = 3.6			Speed 1,500 (rpm)	
Ke (V/Krpm) = 98													Ke (V/krpm) = 216				
5.5	9.5	12.8	16	18.2	10.3	19.4	26.5	33.2	34.2	35.2	36.2	37	67	76	84	Rated Torque (Nm)	
3.9	6.9	9.8	12.8	15.6	7	14.1	20.9	27.8	33.8	39.4	44.4	48.1	25.8	32.5	38.1	Stall Current (A)	
1.73	2.98	4.02	5.03	5.7	3.24	6.09	8.33	10.43	10.74	11.06	11.37	11.62	10.5	11.9	13.2	Rated Power (kW)	
6.20	2.12	1.08	0.7	0.5	2.73	0.7	0.41	0.22	0.17	0.14	0.15	0.08	0.27	0.21	0.15	R (ph-ph) (Ohms)	
42.97	19.11	12.06	8.91	6.7	23.50	10.47	7.35	4.89	3.86	3.6	3.06	2.42	10	8.6	6.6	L (ph-ph) (mH)	
1	1	1	1	1	1.5	1.5	1.5	1.5	1.5	1.5	HYBRID ONLY		1.5	1.5	1.5	Recommended power conn' size	
Kt (Nm/A) = 1.2													Kt (Nm/A) = 2.7			Speed 2,000 (rpm)	
Ke (V/Krpm) = 73.5													Ke (V/krpm) = 162				
4.1	8.1	10.2	12.2	14	8.2	18.2	23	29	N/A	N/A	N/A	N/A	65	73	81	Rated Torque (Nm)	
5.2	9.2	13.1	17.1	20.8	9.4	18.8	27.9	37.1					34.4	43.4	50.9	Stall Current (A)	
1.72	3.37	4.27	5.11	5.86	3.43	7.62	9.63	12.15					10.2	11.5	12.7	Rated Power (kW)	
3.64	1.18	0.61	0.41	0.29	1.35	0.38	0.21	0.14					0.15	0.1	0.08	R (ph-ph) (Ohms)	
24.44	10.54	6.78	5.06	3.97	13.56	6.05	3.86	2.45					5.7	4.2	3.7	L (ph-ph) (mH)	
1	1	1	1.5	1.5	1.5	1.5	1.5	1.5					1.5	HYBRID ONLY		Recommended power conn' size	
Kt (Nm/A) = 0.8													Kt (Nm/A) = 2.1			Speed 2,500 (rpm)	
Ke (V/Krpm) = 49													Ke (V/krpm) = 129				
3.2	5.2	N/A	N/A	N/A	N/A	N/A	N/A	N/A	N/A	N/A	N/A	N/A	62	70	77	Rated Torque (Nm)	
7.8	13.8												43	54.2	63.6	Stall Current (A)	
2.01	3.27												9.7	11	12.1	Rated Power (kW)	
1.63	0.53												0.09	0.08	0.06	R (ph-ph) (Ohms)	
11.08	4.78												3.5	3.1	2.6	L (ph-ph) (mH)	
1	1												HYBRID ONLY			Recommended power conn' size	

- The Unimotor fm 250 servo motor has been designed to give greatest motor efficiency up to a rated, or rms, speed of 1,500rpm. The range does include the optional speeds of 2,000rpm and 2,500rpm. These windings will allow the end user to enter the intermittent speed zone as well as the intermittent torque zone on the 250 motor.
- These higher speed windings are designed with optimum kt values that allow increased speed without demanding very high currents.
- The Unimotor fm 250 is designed for S2 to S6 duties and as such the rms values play an important part in the motor selection for torque and speed.

# Peak torque information

On some of the frame sizes the full peak torque cannot be achieved at the full 100 % rms current level. As shown the 075 motor is not affected by the reduced levels and remains constant up to 100 % rms current, whereas the 250 motors all show a drop at some point along the % rms current line.

U3	Peak factor @ 0 - 100% rms		U6	Peak factor @ 0 - 100% rms	
075	3		075	5	
095	Peak Factor 0% - 88% rms	Peak Factor @ 100% rms	095	Peak Factor @ 100% rms	
	3	2		4.5	
115	Peak Factor 0% - 86% rms	Peak Factor @ 100% rms	115	Peak Factor 0% - 84% rms	Peak Factor @ 100% rms
	3	1.5		4	3.5
142	Peak Factor 0% - 57% rms	Peak Factor @ 100% rms	142	Peak Factor 0% - 57% rms	Peak Factor @ 100% rms
	3	1		4	2.5
190	Peak Factor 0% - 60% rms	Peak Factor @ 100% rms	190	N/A	
	3	2		N/A	
250	Peak Factor 0% - 80% rms	Peak Factor @ 100% rms	250	N/A	
	3	2.5		N/A	

## Unimotor fm peak torque graph

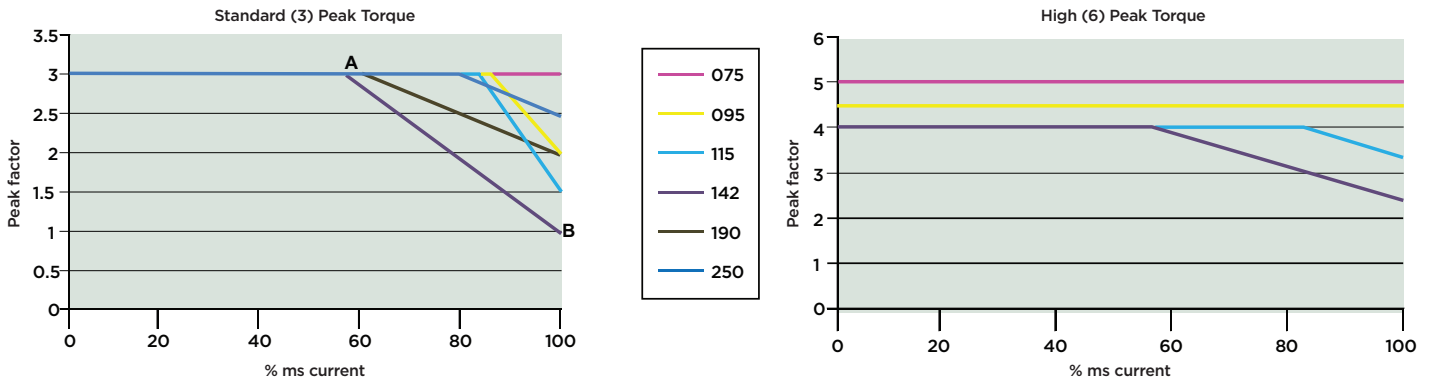

Peak torque is defined for a maximum period of 250ms, rms 3,000 rpm  $\Delta_{max} = 100\text{ }^{\circ}\text{C}$ ,  $40\text{ }^{\circ}\text{C}$  ambient.

To use the graph correctly, you will need to calculate the rms current and rms speed of the application. The rms current value must be converted into a percentage of the full motor current. For example, if the full current available is 10A and the rms current is 7.5A, then the percentage rms current value is 75%. Plot this value onto the graph to obtain the peak factor. The peak factor is then used to calculate the peak torque value using the table to the right.

Peak factor x Stall current x kt = Peak torque		
An example would be with a 142U3E300 motor, where the % rms current value is calculated to 50%, the peak factor would be 3. (Point A)		
Peak factor x Stall current x kt = Peak torque		
3.00	x 15.6	x 1.6 = 74.9 Nm
But if the % rms current were to be calculated at a level of 100%, the peak factor would equal 1.00. (Point B)		
Peak factor x Stall current x kt = Peak torque		
1.00	x 15.6	x 1.6 = 25 Nm



Frame size 075

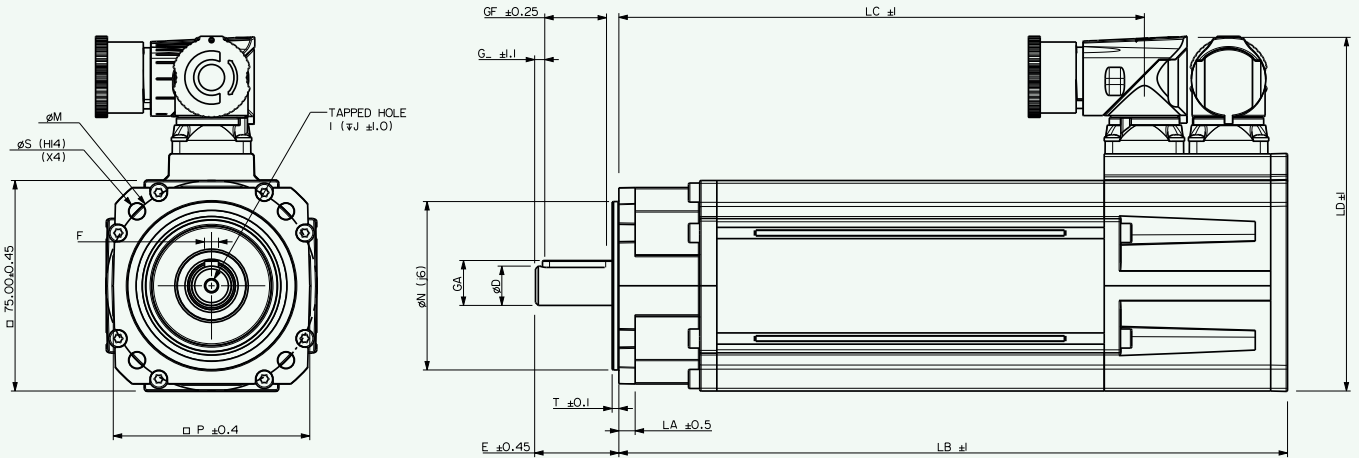

Motor dimensions (mm) Note all dimensions shown are at nominal

Drawing number: IM/0721/GA Iss 4

	Unbraked length		Braked length		Flange thickness LA (± 0.5)	Register length T (± 0.1)	Register diameter N (j6)	Flange square P (± 0.4)	Fixing hole diameter S (H14)	Fixing hole PCD M	Mounting bolts M5
	LB (± 1)	LC (± 1)	LB (± 1)	LC (± 1)							
075A	208.2	157.2	238.2	187.2	5.8	2.4	60.0	70.0	5.8	75.0	M5
075B	238.2	187.2	268.2	217.2							
075C	268.2	217.2	298.2	247.2							
075D	298.2	247.2	328.2	277.2							

Optional flange motor dimensions (mm)

Optional flange dimensions (mm)

	Unbraked length		Braked length	
	LB (± 1)	LC (± 1)	LB (± 1)	LC (± 1)
075A	192.6	141.6	222.6	171.6
075B	222.6	171.6	252.6	201.6
075C	252.6	201.6	282.6	231.6
075D	282.6	231.6	312.6	261.6

PCD code	Front end frame type	Flange square	Fixing hole PCD	Register diameter	Flange thickness	Fixing hole diameter
		P (± 0.4)	M (± 0.4)	N (j6)	LA (± 0.5)	S (H14)
075	Extended	70.0	66.7 - 75.0	60.0	5.8	5.80
080	Extended	70.0	75.0 - 80.0	60.0	5.8	5.80
085	Flat	80.0	85.0	70.0	5.8	7.00

Optional connector height (mm)

Output shaft dimensions (mm)

Connection type	Overall height
	LD (± 1.0)
A	118.5
C	126.0
V	118.5

	Shaft diameter	Shaft length	Key height	Key length	Key to shaft end	Key width	Tapped hole thread size	Tapped hole depth
	D (j6)	E (±0.45)	GA	GF (±0.25)	G (±1.1)	F	I	J (±0.4)
075A	11.0	23.0	12.5	14.0	3.6	4.0	M4x0.7	11
075B-D (Std)	14.0	30.0	16.0	25.0	1.5	5.0	M5x0.8	13.5
075A-D (Opt)	19.0	40.0	21.5	32.0	3.6	6.0	M6x1.0	17.0

Note: Shaft options below the standard (Std) dimensions will require customer approval and may not be covered by warranty.

**Frame size 095**

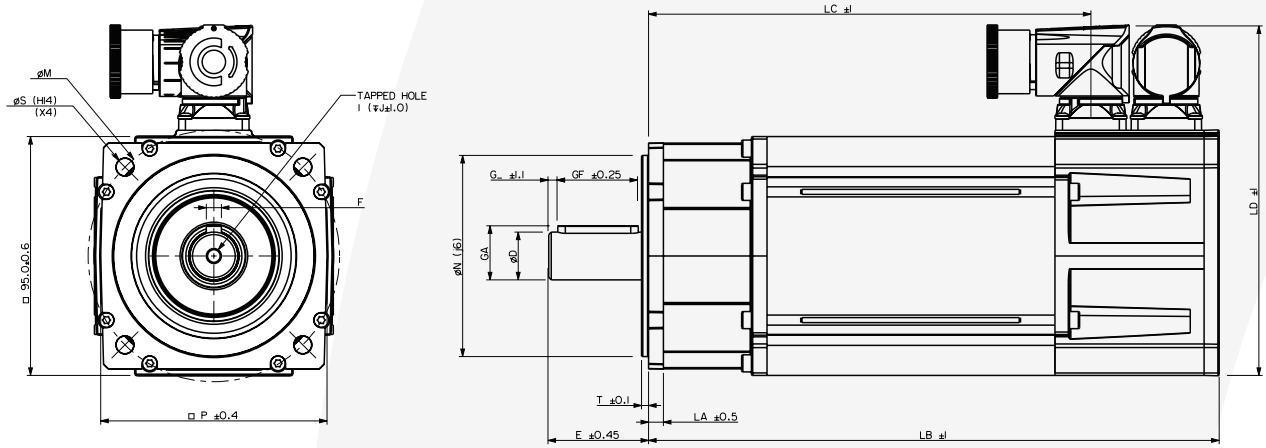

Motor dimensions (mm) Note all dimensions shown are at nominal

**Drawing number: IM/0722/GA Iss 4**

	Unbraked length		Braked length		Flange thickness LA (± 0.5)	Register length T (± 0.1)	Register diameter N (j6)	Flange square P (± 0.4)	Fixing hole diameter S (H14)	Fixing hole PCD M (± 0.4)	Mounting bolts M6
	LB (± 1)	LC (± 1)	LB (± 1)	LC (± 1)							
095A	226.9	175.9	256.9	205.9	5.9	2.8	80.0	90.0	7.0	100.0	M6
095B	256.9	205.9	286.9	235.9							
095C	286.9	235.9	316.9	265.9							
095D	316.9	265.9	346.9	295.9							
095E	346.9	295.9	376.9	325.9							

Optional flange motor dimensions (mm)

Optional flange dimensions (mm)

	Unbraked length		Braked length	
	LB (± 1)	LC (± 1)	LB (± 1)	LC (± 1)
095A	201.8	150.8	231.8	180.8
095B	231.8	180.8	261.8	210.8
095C	261.8	210.8	291.8	240.8
095D	291.8	240.8	321.8	270.8
095E	321.8	270.8	351.8	300.8

PCD code	Front end frame type	Flange square	Fixing hole PCD	Register diameter	Flange thickness	Fixing hole diameter
		P (± 0.4)	M (± 0.4)	N (j6)	LA (± 0.5)	S (H14)
098	Extended	90.0	98.4	73.0	5.9	7.0
115.0	Flat	105.0	115.0	95.0	6.8	10.0

Optional connector height (mm)

Output shaft dimensions (mm)

Connection type	Overall height
	LD (± 1)
A	131.5
C	139.0
V	131.5

	Shaft diameter	Shaft length	Key height	Key length	Key to shaft end	Key width	Tapped hole thread size	Tapped hole depth
	D (j6)	E (±0.45)	GA	GF (±0.25)	G (±1.1)	F	I	J (±0.4)
095 A (Std)	14.0	30.0	16.0	25.0	1.5	5.0	M5x0.8	13.5
095 B-E (Std)	19.0	40.0	21.5	32.0	3.6	6.0	M6x1.0	17.0
095 A-E (Opt)	22.0	50.0	24.5	40.0	4.6	6.0	M8x1.25	20.0

**Note:** Shaft options below the standard (Std) dimensions will require customer approval and may not be covered by warranty.

**Frame size 115**

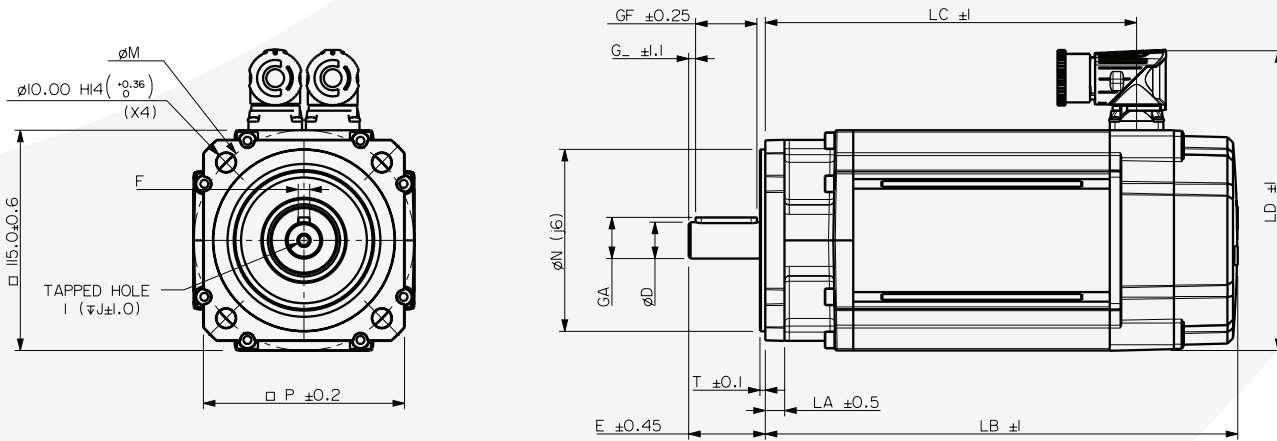

Motor dimensions (mm) Note all dimensions shown are at nominal

**Drawing number: IM/0717/GA Iss 6**

	Unbraked length		Braked length		Flange thickness	Register length	Register diameter	Flange square	Fixing hole diameter	Fixing hole PCD	Mounting bolts
	LB* (± 1)	LC (± 1)	LB* (± 1)	LC (± 1)							
115A	246.6	193.8	276.6	223.8	10.1	2.8	95.0	105.0	10.0	115.0	M8
115B	276.6	223.8	306.6	253.8							
115C	306.6	253.8	336.6	283.8							
115D	336.6	283.8	366.6	313.8							
115E	366.6	313.8	396.6	343.8							

Optional flange motor dimensions (mm)

Optional flange dimensions (mm)

	Unbraked length		Braked length	
	LB* (± 1)	LC (± 1)	LB* (± 1)	LC (± 1)
115A	213.9	161.1	243.9	191.1
115B	243.9	191.1	273.9	221.1
115C	273.9	221.1	303.9	251.1
115D	303.9	251.1	333.9	281.1
115E	333.9	281.1	363.9	311.1

PCD code	Front end frame type	Flange square	Fixing hole PCD	Register diameter	Flange thickness	Fixing hole diameter
		P (± 0.4)	M (± 0.4)	N (j6)	LA (± 0.5)	S (H14)
130.0	Flat	116.0	130.0	110.0	13.2	10.0

Optional connector height (mm)

Output shaft dimensions (mm)

Connection type	Overall height
	LD (± 1)
A	149.0
C	156.5
V	149.0

	Shaft diameter	Shaft length	Key height	Key length	Key to shaft end	Key width	Tapped hole thread size	Tapped hole depth
	D (j6)	E (±0.45)	GA	GF (±0.25)	G (±1.1)	F	I	J (±0.4)
115 A-C (Std)	19.0	40.0	21.5	32.0	3.6	6.0	M6x1.0	17.0
115 D-E (Std)	24.0	50.0	27.0	40.0	4.6	8.0	M8x1.25	20.0

**Note:** Shaft options below the standard (Std) dimensions will require customer approval and may not be covered by warranty.

\* For EC/FC encoders reduce LB length by 13mm. For AE resolvers reduce LB length by 23mm.



## Frame size 142

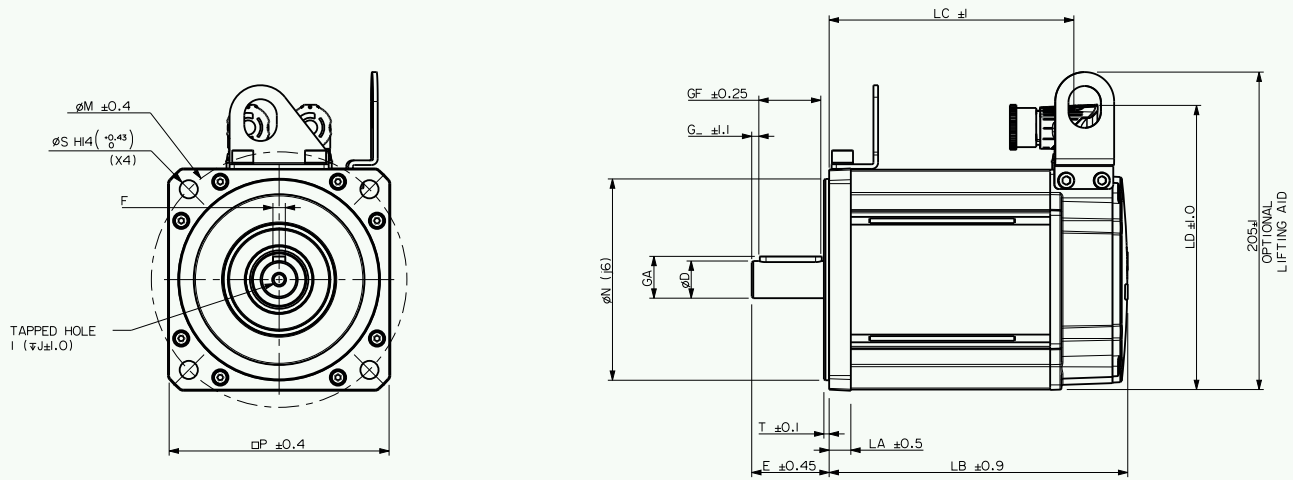

Motor dimensions (mm) Note all dimensions shown are at nominal

Drawing number: IM/0718/GA Iss 8

	Unbraked length		Braked length		Flange thickness	Register length	Register diameter	Flange square	Fixing hole diameter	Fixing hole PCD	Mounting bolts
	LB ( $\pm 1$ )	LC ( $\pm 1$ )	LB ( $\pm 1$ )	LC ( $\pm 1$ )							
142A	192.8	158.0	252.8	218.0	14.0	3.4	130.0	142.0	12.0	165.0	M10
142B	222.8	188.0	282.8	248.0							
142C	252.8	218.0	312.8	278.0							
142D	282.8	248.0	342.8	308.0							
142E	312.8	278.0	372.8	338.0							

Optional flange motor dimensions (mm)

Optional flange dimensions (mm)

	Unbraked length		Braked length	
	LB ( $\pm 1$ )	LC ( $\pm 0.9$ )	LB ( $\pm 0.9$ )	LC ( $\pm 1$ )
142A	241.8	207.0	301.8	267.0
142B	271.8	237.0	331.8	297.0
142C	301.8	267.0	361.8	327.0
142D	331.8	297.0	391.8	357.0
142E	361.8	327.0	421.8	387.0

PCD code	Front end frame type	Flange square	Fixing hole PCD	Register diameter	Flange thickness	Fixing hole diameter
		P ( $\pm 0.4$ )	M ( $\pm 0.4$ )	N (j6)	LA ( $\pm 0.5$ )	S (H14)
149.0	Extended	140.0	149.2	114.3	11.5	12.0

Optional connector height (mm)

Output shaft dimensions (mm)

Connection type	Height	Connector type	Height
	LD ( $\pm 1$ )		LD ( $\pm 1$ )
A	176.0	J	204.5
C	183.5	M	184.0
V	176.0		

	Shaft diameter	Shaft length	Key height	Key length	Key to shaft end	Key width	Tapped hole thread size	Tapped hole depth
	D (j6)	E ( $\pm 0.45$ )	GA	GF ( $\pm 0.25$ )	G ( $\pm 1.1$ )	F	I	J ( $\pm 0.4$ )
142 A-E (Opt)	22.0	50.0	24.5	40.0	4.6	6.0	M8x1.25	20.0
142 A-E (Std)	24.0	50.0	27.0	40.0	4.6	8.0	M8x1.25	20.0
142 A-E (Opt)	28.0	60.0	31.0	50.0	4.6	8.0	M10x1.5	23.0
142 A-E (Opt)	32.0	58.0	35.0	50.0	4.6	10.0	M12x1.75	29.0

Note: Shaft options below the standard (Std) dimensions will require customer approval and may not be covered by warranty.

Lifting brackets fitted if required.

Frame size 190

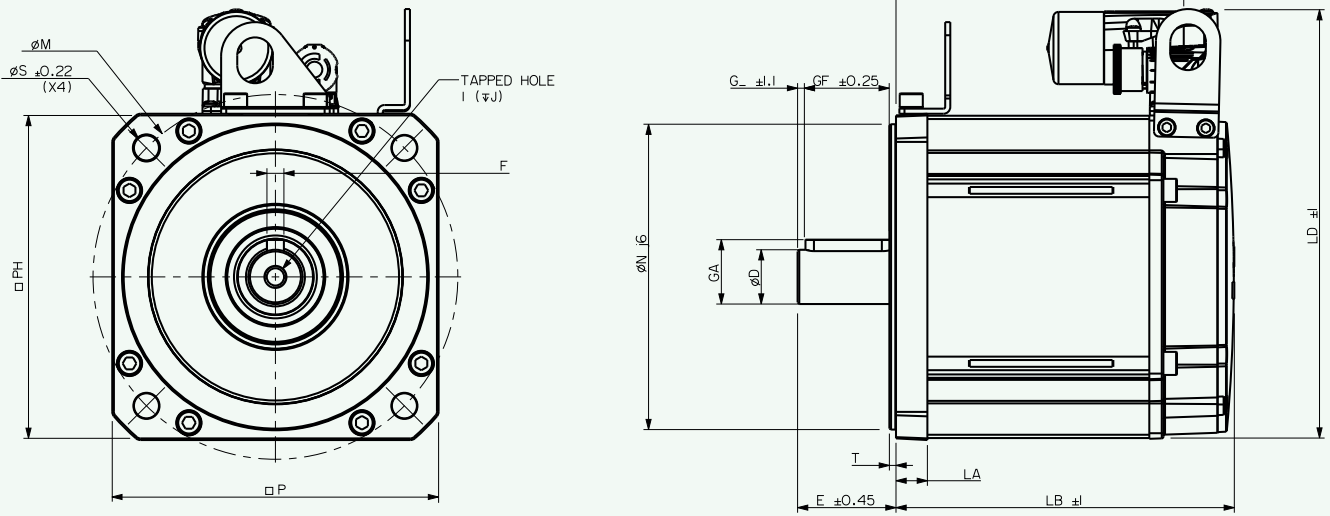

Motor dimensions (mm) Note all dimensions shown are at nominal

Drawing number: IM/0723/GA Iss 4

	Unbraked length		Braked length		Flange thickness LA (± 0.5)	Register length T (± 0.1)	Register diameter N (j6)	Flange square P (± 0.4)	Fixing hole diameter S (H14)	Fixing hole PCD M (± 0.4)	Mounting bolts M12
	LB (± 1)	LC (± 1)	LB (± 1)	LC (± 1)							
190A	199.4	169.6	289.4	259.6	18.5	3.9	180.0	190.3	14.5	215.0	M12
190B	229.4	199.6	319.4	289.6							
190C	259.4	229.6	349.4	319.6							
190D	289.4	259.6	379.4	349.6							
190E	319.4	289.6	409.4	379.6							
190F	349.4	319.6	439.4	409.6							
190G	379.4	349.6	469.4	439.6							
190H	409.4	379.6	499.4	469.6							

Output shaft dimensions (mm)

	Shaft diameter D (j6)	Shaft length E (±0.45)	Key height GA	Key length GF (±0.25)	Key to shaft end G (±1.1)	Key width F	Tapped hole thread size I	Tapped hole depth J (±0.4)
190 A-H (Opt)	28.0	60.0	31.0	50.0	4.6	8.0	M10x1.5	23.0
190 A-H (Std)	32.0	58.0	35.0	50.0	4.6	10.0	M12x1.75	29.0
190 A-H (Opt)	38.0	58.0	41.0	50.0	4.6	10.0	M12x1.75	29.0
190 A-H (Opt)	42.0	110.0	45.0	100.0	4.6	12.0	M16x2.0	37.0

Note: Shaft options below the standard (Std) dimensions will require customer approval and may not be covered by warranty.

Optional connector height (mm)

Connection type	Overall height
	LD (± 1)
M	232.0
N	252.5
H (<40 Amp)	287.0
H (<60 Amp)	323.0

**Frame size 250**

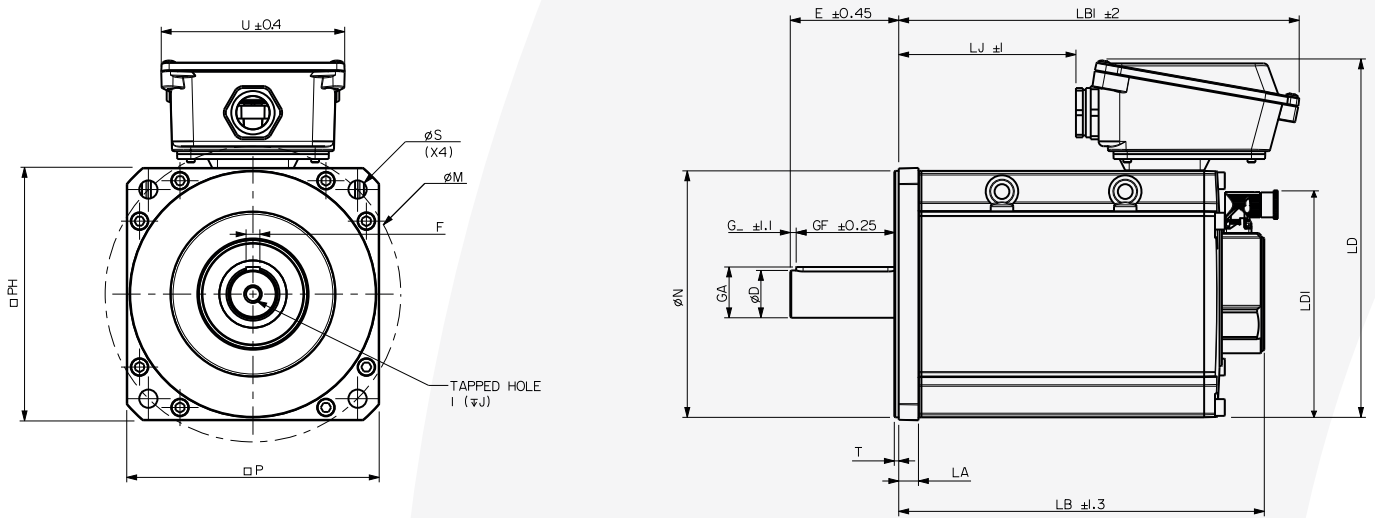

Motor dimensions (mm) Note: all dimensions shown are at nominal

**Drawing number: IM/0672/GA Iss 5**

	Motor Length			Flange thickness	Register length	Register diameter	Overall height	Flange square	Fixing hole diameter	Fixing hole PCD	Motor housing	Hybrid box width	Signal connector height	Mounting bolts
	LB (± 1.3)	LB1 (± 2.0)	LJ (± 1.0)											
	Unbraked motor			20.0	4.5	250.0	363.5	256.0	18.5	300.0	250.0	186.0	228.5	M16
250D	375.7	406.1	179.7											
250E	405.7	436.1	209.7											
250F	435.7	466.1	239.7											
	Braked motor													
250D	447.5	477.9	251.5											
250E	477.5	507.9	281.5											
250F	507.5	537.9	311.5											

**Note:** For Heidenhain feedback devices please add 15mm to LB length

Output shaft dimensions (mm)

	Shaft diameter	Shaft length	Key height	Key length	Key to shaft end	Key width	Tapped hole thread size	Tapped hole depth
	D (j6)	E (±0.45)	GA (IEC 72-1)	GF (±0.25)	G (±1.1)	F (H9)	I	J (±1.0)
38.0 (Opt)	38.0	80.0	41.0	70.0	4.6	10.0	M12x1.75	29.0
42.0 (Opt)	42.0	110.0	45.0	100.0	6.0	12.0	M16x2.0	37.0
48.0 D-F (Std)	48.0	110.0	51.5	100.0	6.0	14.0	M16x2.0	37.0

**Note:** Shaft options below the standard (Std) dimensions will require customer approval and may not be covered by warranty.

Optional connector height (mm)

Connection type	Overall height	Signal overall height
	LD (± 1)	LD1 (± 1)
M	291.5	221.0
N	312.5	221.0
J	312.5	221.0



# Motor derating

Any adverse operating conditions require that the motor performance be derated. These conditions include: ambient temperature above 40 °C, motor mounting position, drive switching frequency or the drive being oversized for the motor.

## Ambient temperatures

The ambient temperature around the motor must be taken into account. For ambient temperatures above 40 °C the torque must be derated using the following formula as a guideline. (Note: Only applies to 2,000/3,000 rpm motors and assumes copper losses dominate.)

New derated torque  
 = Specified torque ×  $\sqrt{1 - ((\text{Ambient temperature} - 40^\circ\text{C}) / 100)}$

For example with an ambient temperature of 76°C the new derated torque will be 0.8 x specified value.

## Thermal test conditions

The performance data shown has been recorded under the following conditions. Ambient temperature 20°C, with the motor mounted on a thermally isolated aluminium plate as shown below.

## Mounting arrangements

The motor torque must be derated if:

- The motor mounting surface is heated from an external source, such as a gearbox.
- The motor is connected to a poor thermal conductor.
- The motor is in a confined space with restricted air flow.

## Drive switching frequency

Most Unidrive M and Digitax ST nominal current ratings are reduced for the higher switching frequencies. See the appropriate drive manual for details.

See the table below for the motor derate factors. These figures are for guidance only.

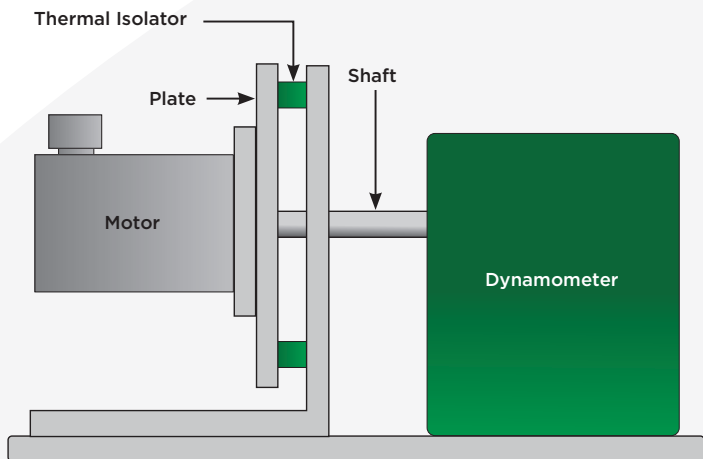

Motor type/frame	Aluminium heatsink plate
075-095 mm	250 x 250 x 15mm
115-142 mm	350 x 350 x 20mm
190-250 mm	500 x 500 x 20mm

## Unimotor fm derate factors

Switching frequency	075		095		115		142		190		250
	A-D	A-E	A-C	D-E	A-C	D-E	A-B	C-H	D-F		
3kHz	0.93	0.88	0.89	0.84	0.87	0.81	0.98	N/A	0.88		
4kHz	0.94	0.91	0.91	0.84	0.91	0.86	0.99	0.55	0.90		
6kHz	0.95	0.93	0.93	0.90	0.94	0.89	0.99	0.77	0.94		
8kHz	0.98	0.91	0.97	0.95	0.97	0.96	1	0.90	0.98		
12/16kHz	1	1	1	1	1	1	1	1	1		

**Note:** Only applies to motors up to 3,000 rpm (rms) or lower. Assumes copper losses dominate on all frame sizes. Derate factor is applied to stall torque, rated torque, stall current and rated power.

# Additional Motor Weights

Additional motor weight information (kg)																														
Motor Frame Size	075				095					115					142					190								250		
Frame Length	A	B	C	D	A	B	C	D	E	A	B	C	D	E	A	B	C	D	E	A	B	C	D	E	F	G	H	D	E	F
Braked '5' Brake	+0.5				+0.6					+1.2					+1.7					+3.5								+11.0		
Braked '6' Brake										+1.78					+2.28															
High Inertia	+0.17				+0.51					+0.94					+1.68					+2.25								+4.88	+5.7	+6.91
Fan Box	+1.2				+1.35					+1.65					+1.9					+2.6								+4.2		
Hybrid Box Small	+0.5				+0.5					+0.5					+0.5															
Hybrid Box Medium															+0.5					+0.5										
Hybrid Box Large																				+1.5								+1.5		

**Note:** All motor weights approximate to ± 10%. Can differ depending on winding, connector and feedback type, PCD and output shaft size.

# Feedback selection

Feedback device order code	Feedback type	Manufacturer	Encoder supply voltage	SinCos cycle or incremental pulses per revolution	Resolution available to position loop2&3	Absolute multi-turn revolutions	Feedback accuracy <sup>1</sup>	Serial communication protocol	Frame size
<b>075-250 Motors</b>									
AE	Resolver	Size 52	6 Vdc Excitation 6kHz	1 Transformation ratio 0.31	Medium 16384 (14 bits)	-	Low +/- 720"	-	-
CA	Incremental Encoder	CFS50	5 Vdc ± 10%	4096	Medium 16384 (14 bits)	-	High +/- 60"	-	-
EC (Multi-turn)	Inductive EnDat SinCos	EQI 1331	4.75 - 10 Vdc	32	High 5.24 x 10 <sup>5</sup> (19 bits)	4096 (12 bits)	Medium +/- 380"	EnDat 2.2 / EnDat 01	Not available on 250 frames
FC (Single-turn)		ECI 1319				-			
EF (Multi-turn)	Inductive EnDat Functional Safety	EQI 1331 FS	3.60 - 14 Vdc	Serial Only	High 5.24 x 10 <sup>5</sup> (19 bits)	4096 (12 bits)	High +/- 65"	EnDat 2.2 / EnDat 22	-
FF (Single-turn)		ECI 1319 FS				-			-
RA (Multi-turn)	Optical Hiperface SinCos	SRM 50	7 - 12 Vdc	1024	High 1.04 x 10 <sup>6</sup> (20 bits)	4096 (12 bits)	High +/- 52"	Hiperface	-
SA (Single-turn)		SRS 50				-			-
EB (Multi-turn)	Optical EnDat SinCos	EQN 1325	3.6 - 14 Vdc	2048	High 2.08 x 10 <sup>6</sup> (21 bits)	4096 (12 bits)	Very High +/- 20"	EnDat 2.2 / EnDat 01	-
FB (Single -turn)		ECN 1313				-			-
NA	Sensorless	-	-	-	-	-	-	-	fm only

<sup>1</sup> The information is supplied by the feedback device manufacturer and relates to it as a standalone device. The value may change when mounted into the motor and connected to a drive. These values have not been verified by Control Techniques

<sup>2</sup> The output from the resolver is an analogue output; the resolution is determined by the analogue to digital converter used; the value shown is when the resolver is used in conjunction with the SM-Resolver.

<sup>3</sup> The sin and cosine outputs from the SinCos optical encoders are analogue outputs; with Unidrive M and Digitax ST the resolutions quoted above are when the encoder type is set to either SC Endat or SC Hiperface depending on the encoder.

# Feedback terminology

## Resolver

A passive wound device consisting of a stator and rotor elements excited from an external source, such as an SM-Resolver, the resolver produces two output signals that correspond to the Sine and CoSine angle of the motor shaft. This is a robust absolute device of low accuracy, capable of withstanding high temperature and high levels of vibration. Positional information is absolute within one turn - i.e. position is not lost when the drive is powered down.

## Incremental encoder

An electronic device using an optical disc. The position is determined by counting steps or pulses. Two sequences of pulses in quadrature are used so the direction sensing may be determined and 4x (pulses per rev) may be used for resolution in the drive. A marker pulse occurs once per revolution and is used to zero the position count. The encoder also provides commutation signals, which are required to determine the absolute position during the motor phasing test. This device is available in 4096, 2048 and 1024 ppr versions. Positional information is non absolute - i.e. position is lost when the drive is powered down.

## SinCos / absolute encoders

Types available are: Optical or Inductive - which can be single or multi-turn.

### 1) Optical

An electronic device using an optical disc. An absolute encoder with high resolution that employs a combination of absolute information, transmitted via a serial link, and Sine/CoSine signals with incremental techniques.

### 2) Inductive / Capacitive

An electronic device using inductively coupled PCBs. An absolute encoder with medium resolution the employs a combination of absolute information, transmitted via a serial link, and Sine/CoSine signals with incremental techniques. This encoder can be operated with the drive using either Sine/CoSine or absolute (serial) values only. Positional information is absolute within 4096 turns - i.e. position is not lost when the drive is powered down.

## Multi-turn

As previous but with extra gear wheels included so that the output is unique for each shaft position and the encoder has the additional ability to count complete turns of the motor shaft up to 4096 revolutions

## Sensorless

Synchronous Rotor Flux Control. Recommended for use on the fm motor range. The motor performance will be limited when operating at low speed when using high frequency injection mode. When using closed loop vector mode the motor performance will be as stated in the ratings tables.

## Environment

The environment is the external conditions that physically surround the Feedback device. The main factors that affect the feedback device are temperature and mechanical shock and vibration.

Motors are designed to allow the feedback devices to be within their operational temperature limits. Generally it is assumed that there is free air movement around the motor. If the motor is positioned where there is little or no airflow or it is connected to a heat source such as a gearbox, it can cause the air temperature around the feedback device to be operating outside its recommended operating temperature and can lead to problems.

Mechanical shock and vibration tends to be transmitted from the load through the motor shaft and into the feedback device. This should be considered when the motor and feedback device are being specified for the application.

## Position

The defined position is the location in a coordinate system which is usually in two or more dimensions.

For a rotary feedback device this is defined as the location within one revolution. If it is a multi-turn device it is the location within one revolution plus the location within a number of rotations.

For a linear feedback device this is defined as the distance from a known point.

## Resolution

The resolution of a feedback device is the smallest change in position or angle that it can detect in the quantity that it is measuring.

Feedback resolution of the system is a function of the type of feedback device used and drive receiving the information.

Generally, as the resolution of the feedback device increases the level of control that can be used in the servo system increases.

As with accuracy, as the resolution of the device increases the cost increases.

## Accuracy

Accuracy is the measure of the difference between the expected position and actual measured value. Rotary feedback accuracy is usually given as an angle representing the maximum deviation from the expected position. Linear feedback accuracy is usually given as a distance representing the maximum deviation from the expected.

Generally, as the accuracy increases the cost of the feedback device increases.

# Brake specification

Unimotor fm may be ordered with an internal rear mounted spring applied parking brake. The brake works on a failsafe principle. The brake is active when the supply voltage is switched off, and the brake is released when the supply voltage is switched on.

If a motor is fitted with a failsafe brake, take care not to subject the motor shaft to excessive torsional shocks or resonance when the brake is engaged or disengaged. Doing so can damage the brake.

## SAFETY NOTE

The failsafe brake is for use as a holding brake with the motor shaft stationary.

Do NOT use it as a dynamic brake. Using it in this manner will cause brake wear and eventual failure. Emergency Stop situations can contribute to brake wear and failure.



**Note:** Shunting the brake primary coil with an external diode to avoid switching peaks increases the release time considerably. This is usually required to protect solid state switches, or to reduce arcing at the brake relay contacts (Diode 1N4001 recommended)

“Resin” Friction Material Application & Benefits:

- The main features change to the type 6 brake is the use of an improved Resin friction material compared to its predecessors.
- The type 6 brake has improved overall performance in operation compared to the aluminium cored friction materials containing natural rubber.
- Type 6 brakes can endure higher interface temperatures and pressures.
- Type 6 brake disk are moulded as a one-piece part providing better tensile, compressive & impact qualities compared to other friction materials.

## Unimotor fm

Motor frame	Supply volts	Input power	Static torque	Release time	Moment of inertia	Backlash **
			Parking Brake (5)			
Size	Vdc	W	Nm	ms nom	kg.cm <sup>2</sup> *	Degrees **
075	24	6.3	2.2	22	0.07	1.03
095	24	16	12.2	60	0.39	0.75
115	24	23	20	126	0.21	0.75
142	24	23	20	126	0.21	0.75
190 (A-D)	24	25	42	95	1.85	0.77
190 (E-H)	24	25	67	120	4.95	0.77
250	24	62	135	252	14.3	0.5

Motor frame	Supply volts	Input power @ 20 °C	Static torque	Release time	Moment of inertia	Backlash **
			Parking Brake (5)			
Size	Vdc	W	Nm	ms nom	kg.cm <sup>2</sup> *	Degrees **
115	24	17.5	16	64	consult factory	0.38°
142	24	17.5	16	64	consult factory	0.38°

\*Note 1 kg.cm2 = 1 x 10<sup>-4</sup> kg.m2 \*\* Backlash figure will increase with time

- The brake is intended for parking duty and is not for dynamic or safety use.
- Refer to your Automation Center or Distributor if your application requires dynamic braking in emergency conditions.
- To provide protection to the brake control circuit it is recommended that a diode is connected across the output terminals of the solid state or relay contacts devices.
- Larger torque brakes are available as an option. Contact your Automation Center or Distributor for details.
- Figures are shown at 20 °C brake temperature. Apply the derate factor of 0.9 to the high energy brake if motor temperature is above 100 °C.
- The brake will engage when power is removed.

It is recommended to run extensive application validation testing and confirm the motor brake life span when the motor is mounted vertically and the motor runs through high acceleration and deceleration.



### Power plug

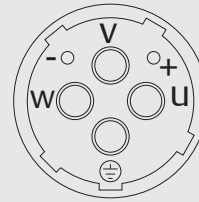
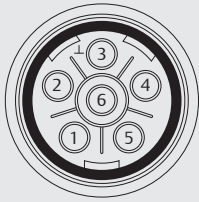

Size 1	With brake	Without brake	Size 1.5	With brake	Without brake
Pin	Function	Function	Pin	Function	Function
1	Phase U (R)	Phase U (R)	U	Phase U (R)	Phase U (R)
2	Phase V (S)	Phase V (S)	V	Phase V (S)	Phase V (S)
3	Ground	Ground	⊕	Ground	Ground
4	Phase W (T)	Phase W (T)	W	Phase W (T)	Phase W (T)
5	Brake		+	Brake	
6	Brake		-	Brake	
Shell	Screen	Screen	Shell	Screen	Screen

### Signal plug

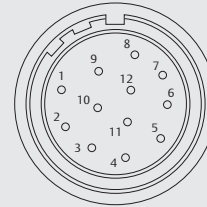
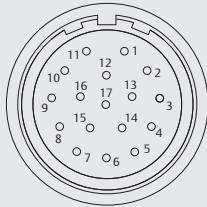

	Incremental encoder (CA, MA)	Heidenhain Sincos absolute encoders (EM, FM, EC, FC, EF, FF, EB, FB)	Resolver (AE)	SICK Sin/Cos encoders (RA, SA)
Pin	Function	Function	Function	Function
1	Thermistor	Thermistor	Excitation High	REF Cos
2	Thermistor	Thermistor	Excitation Low	+ Data
3		Screen (Optical only)	Cos High	- Data
4	S1		Cos Low	+ Cos
5	S1 Inverse		Sin High	+ Sin
6	S2		Sin Low	REF Sin
7	S2 Inverse		Thermistor	Thermistor
8	S3	+ Clock	Thermistor	Thermistor
9	S3 Inverse	- Clock		Screen
10	Channel A	+ Cos		0 Volts
11	Index	+ Data		-
12	Index Inverse	- Data		+ V
13	Channel A Inverse	- Cos		
14	Channel B	+ Sin		
15	Channel B Inverse	- Sin		
16	+ V	+ V		
17	0 Volts	0 Volts		
Body	Screen	Screen		Screen

# Notes:

# Notes:

Connect with us at:



[www.controltechniques.com](http://www.controltechniques.com)



© 2018 Nidec Control Techniques Limited. The information contained in this brochure is for guidance only and does not form part of any contract. The accuracy cannot be guaranteed as Nidec Control Techniques Ltd have an ongoing process of development and reserve the right to change the specification of their products without notice.

Nidec Control Techniques Limited. Registered Office: The Gro, Newtown, Powys SY16 3BE. Registered in England and Wales. Company Reg. No. 01236886.